

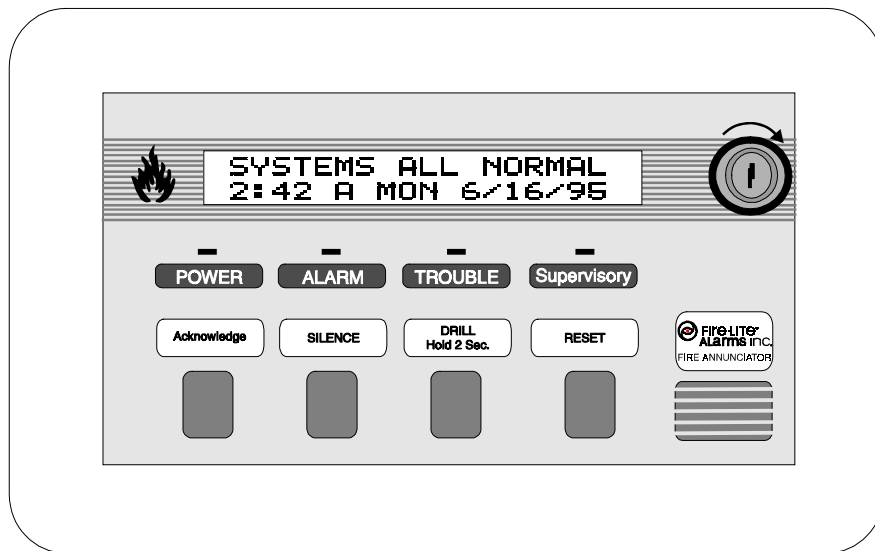

12 Clintonville Road  
Northford, CT 06472  
Phone: (203) 484-7161  
FAX: (203) 484-7118

# The LCD-40 Series Remote Fire Annunciators

*for use with Fire-Lite  
MS-9200  
Addressable Fire Alarm Control Panel*



Document # 50327  
11/6/97 Revision: **D**  
P/N 50327:D ECN 97-466

## Installation Precautions

**WARNING** - Several different sources of power can be connected to the fire alarm control panel. Disconnect all sources of power before servicing. Control unit and associated equipment may be damaged by removing and/or inserting cards, modules, or interconnecting cables while the unit is energized. Do not attempt to install, service, or operate this unit until this manual is read and understood.

**CAUTION** - *System Reacceptance Test after Software Changes:* To ensure proper system operation, this product must be tested in accordance with NFPA 72-1993 Chapter 7 after any programming operation or change in site-specific software. Reacceptance testing is required after any change, addition or deletion of system components, or after any modification, repair or adjustment to system hardware or wiring.

All components, circuits, system operations, or software functions known to be affected by a change must be 100% tested. In addition, to ensure that other operations are not inadvertently affected, at least 10% of initiating devices that are not directly affected by the change, up to a maximum of 50 devices, must be tested and proper system operation verified.

**This system** meets NFPA requirements for operation at 0-49° C/32-120° F and at a relative humidity of 85% RH (non-condensing) at 30° C/86° F. However, the useful life of the system's standby batteries and the electronic components may be adversely affected by extreme temperature ranges and humidity. Therefore, it is recommended that this system and its peripherals be installed in an environment with a nominal room temperature of 15-27° C/60-80° F.

**Verify that wire sizes are adequate** for all initiating and indicating device loops. Most devices cannot tolerate more than a 10% I.R. drop from the specified device voltage.

Adherence to the following will aid in problem-free installation with long-term reliability:

**Like all solid state electronic devices**, this system may operate erratically or can be damaged when subjected to lightning induced transients. Although no system is completely immune from lightning transients and interferences, proper grounding will reduce susceptibility. *Overhead or outside aerial wiring is not recommended, due to an increased susceptibility to nearby lightning strikes.* Consult with the Technical Services Department if any problems are anticipated or encountered.

**Disconnect AC power and batteries** prior to removing or inserting circuit boards. Failure to do so can damage circuits.

**Remove all electronic assemblies** prior to any drilling, filing, reaming, or punching of the enclosure. When possible, make all cable entries from the sides or rear. Before making modifications, verify that they will not interfere with battery, transformer, and printed circuit board location.

**Do not tighten screw terminals** more than 9 in-lbs. Over tightening may damage threads, resulting in reduced terminal contact pressure and difficulty with screw terminal removal.

**This system** contains static-sensitive components. Always ground yourself with a proper wrist strap before handling any circuits so that static charges are removed from the body. Use static suppressive packaging to protect electronic assemblies removed from the unit.

**Follow the instructions** in the installation, operating, and programming manuals. These instructions must be followed to avoid damage to the control panel and associated equipment. FACP operation and reliability depend upon proper installation.

---

## Fire Alarm System Limitations

**An automatic fire alarm system** - typically made up of smoke detectors, heat detectors, manual pull stations, audible warning devices, and a fire alarm control with remote notification capability can provide early warning of a developing fire. Such a system, however, does not assure protection against property damage or loss of life resulting from a fire.

**Any fire alarm system** may fail for a variety of reasons:

**Smoke detectors** may not sense fire where smoke cannot reach the detectors such as in chimneys, in walls, or roofs, or on the other side of closed doors. Smoke detectors also may not sense a fire on another level or floor of a building. A second floor detector, for example, may not sense a first floor or basement fire. Furthermore, all types of smoke detectors - both ionization and photoelectric types, have sensing limitations. No type of smoke detector can sense every kind of fire caused by carelessness and safety hazards like smoking in bed, violent explosions, escaping gas, improper storage of flammable materials, overloaded electrical circuits, children playing with matches, or arson.

**IMPORTANT!** *Smoke detectors must be installed in the same room as the control panel and in rooms used by the system for the connection of alarm transmission wiring, communications, signaling, and/or power.* If detectors are not so located, a developing fire may damage the alarm system, crippling its ability to report a fire.

---

*While installing a fire alarm system may make lower insurance rates possible, it is not a substitute for fire insurance!*

**Audible warning devices** such as bells may not alert people if these devices are located on the other side of closed or partly open doors or are located on another floor of a building.

**A fire alarm system** will not operate without any electrical power. If AC power fails, the system will operate from standby batteries only for a specified time.

**Rate-of-Rise heat detectors** may be subject to reduced sensitivity over time. For this reason, the rate-of-rise feature of each detector should be tested at least once per year by a qualified fire protection specialist.

**Equipment used in the system** may not be technically compatible with the control. It is essential to use only equipment listed for service with your control panel.

**Telephone lines** needed to transmit alarm signals from a premise to a central monitoring station may be out of service or temporarily disabled.

**The most common cause** of fire alarm malfunctions, however, is inadequate maintenance. All devices and system wiring should be tested and maintained by professional fire alarm installers following written procedures supplied with each device. System inspection and testing should be scheduled monthly or as required by National and/or local fire codes. Adequate written records of all inspections should be kept.

# Contents

|   |           |
|---|-----------|
| <b>Section One: General Information</b> .....                   | <b>4</b>  |
| General .....   | 4         |
| Features .....  | 4         |
| Figure 1-1: Component Summary .....                             | 5         |
| Figure 1-2: Wiring to Terminals .....                           | 6         |
| SW1 DIP Switch Settings .....                                   | 7         |
| Figure 1-2: DIP Switch Settings Example .....                   | 7         |
| Figure 1-3: Typical Configuration .....                         | 8         |
| <b>Section Two: Operation</b> .....                             | <b>9</b>  |
| Display Patterns .....  | 9         |
| Switch Functions .....  | 10        |
| Acknowledge/Step Switch .....                                   | 10        |
| Silence Switch .....  | 10        |
| Drill Switch .....  | 11        |
| System Reset Switch .....                                       | 11        |
| LED Indicators .....  | 11        |
| <b>Section Three: Mounting</b> .....                            | <b>12</b> |
| Figure 3-1: LCD-40 Series Hardware .....                        | 12        |
| Figure 3-2: LCD-40 Series Backboxes .....                       | 12        |
| Figure 3-3: Semi-flush Mounting .....                           | 13        |
| Figure 3-4: Surface Mounting .....                              | 14        |
| <b>Section Four: LCD-40 Series Electrical Connections</b> ..... | <b>15</b> |
| Figure 4-1: Power Connection .....                              | 15        |
| Figure 4-2: EIA-485 Connection .....                            | 16        |
| Figure 4-3: DIM-485 Connections .....                           | 17        |
| Figure 4-4: Wiring FACP to LCD-40 Series .....                  | 18        |
| <b>Section Five: EIA-485 Shield Terminations</b> .....          | <b>19</b> |
| When the EIA-485 Shield is not in Conduit .....                 | 19        |
| When the EIA-485 Shield is in Full Conduit .....                | 20        |
| <b>Section Six: Programming the MS-9200</b> .....               | <b>21</b> |

## Section One: LCD-40 Series Annunciators

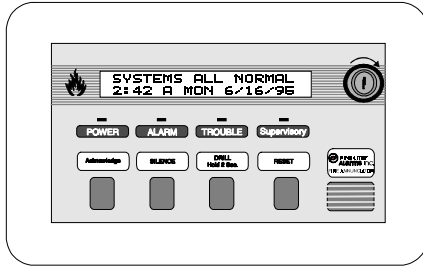

**LCD-40**

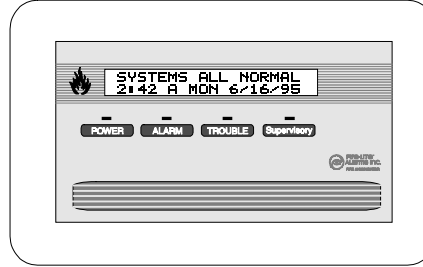

**LCD-40L**

The Fire•Lite LCD-40 Series Annunciators are compact, attractive, 40-character, backlit LCD fire annunciators designed for use with the MS-9200 Addressable Fire Alarm Control Panel. The LCD-40L operates the same as the LCD-40 except it does not have function switches or a key-switch. *It should be noted that the LCD-40 Series Annunciator displays mimic the LCD display located on the MS-9200 main circuit board. To ensure that the LCD-40 will operate with the MS-9200(E), the following software must be installed:*

*If the MS-9200 has software with a Part Number 73750 or 73829 installed, the LCD-40 Series Annunciator must have software with a Part Number 73779 or 73879 installed in order to operate correctly with the FACP.*

*If the MS-9200 has software with a Part Number #M9200V20 or higher installed, the LCD-40 must have software with a Part Number #LCD40V20 or higher installed in order to operate correctly with the FACP.*

*If the MS-9200 Export Version has software with a Part Number 73846 installed, the LCD-40 Series Annunciator must have software with a Part Number 73779 or 73879 installed in order to operate correctly.*

*If the MS-9200 Export Version has software with a Part Number #M9200EV20 or higher installed, the LCD-40 must have software with a Part Number #LCD40V20 or higher installed in order to operate correctly with the FACP.*

The LCD-40 Series is capable of displaying English-language text of system point status including device type, independent *point* alarm, trouble or supervisory, zone and custom alpha labels programmed into the control panel. The LCD-40 Series also provide system status LEDs to display Power, Alarm, Trouble and Supervisory conditions. The LCD-40 is capable of performing system acknowledge, silence, drill and reset remotely while the LCD-40L does not have these features.

Communication between the control panel and the LCD-40 Series is accomplished over a two-wire serial interface employing the EIA-485 communication standard. Up to 32 annunciators may be connected to the two-wire EIA-485 circuit. The annunciators may be powered from the host FACP or remote UL listed, filtered, regulated power supplies.

### Features - LCD-40 and LCD-40L

- 40-character LCD display (20 characters x 2 lines) is backlit under normal and alarm conditions.
- System Status LEDs for Power (green), Alarm (red), Trouble (yellow) and Supervisory (yellow)
- No programming necessary — duplicates messages at control panel display.

- Local piezo sounder with alarm and trouble resound.
  - Device type identifiers from the control panel.
  - Device & zone custom alpha labels from the control panel.
  - Time/date and device address from the control panel.
  - EIA-485 connects to control panel terminal port (requires DIM-485 module).
  - Plug-in terminal blocks for ease of installation and service.
  - DIP switches control piezo enable/disable and transmit/receive mode.
  - Up to 32 LCD-40 Series Annunciators per MS-9200.
- Mounting options:
    - Surface mounting in SBB-3 (2.75" depth) or
    - semi-flush mounting in three-gang electrical box (Fire•Lite P/N 10103) with a minimum depth of 2.187"
    - Can be located up to 3,000 feet from the panel
  - Backlight turns off during AC loss to conserve battery power, but will turn back on if an alarm condition occurs.

### Features - LCD-40 Only

- Enable/Disable key-switch.
- Function switches for:
  - Acknowledge
  - Signal Silence
  - Drill
  - System Reset
- DIP switches control function switches and key-switch enable/disable

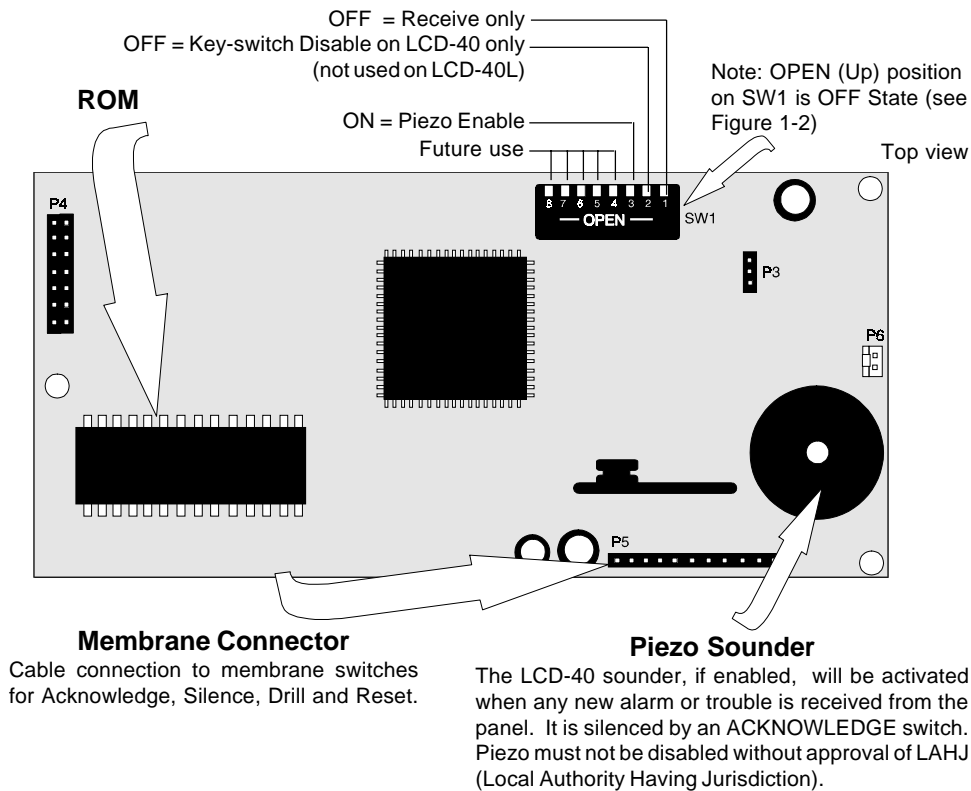

**Figure 1-1: Component Summary**

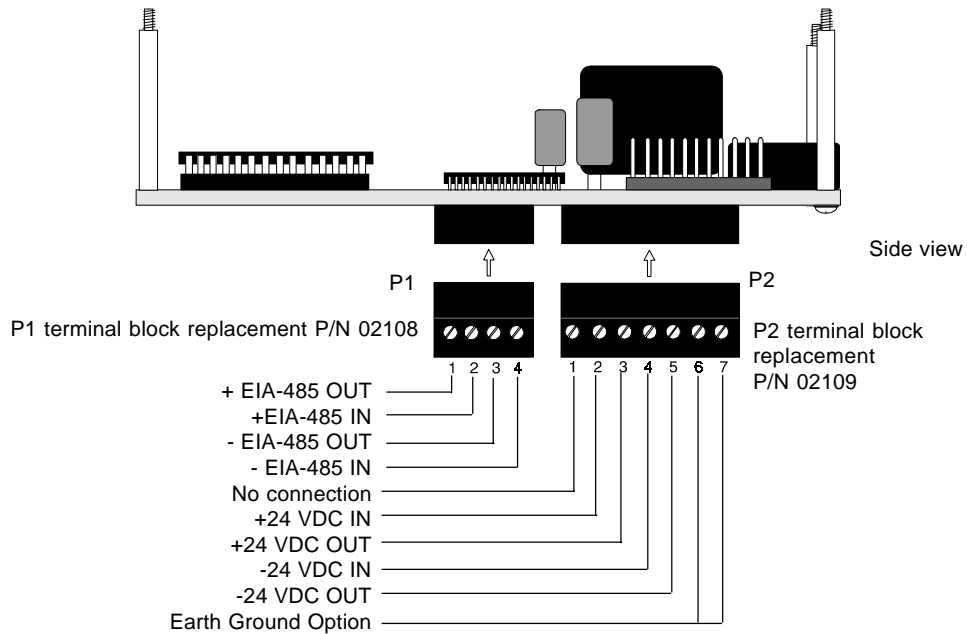

**Note:** These connections must be power-limited and the +24 volt nominal power must be filtered and nonresettable.

| Current Consumption @ 24 VDC nominal (filtered and nonresettable) |       |
|---|-------|
| Normal/Standby (no activity):                                     | 54 mA |
| Trouble Condition:  | 54 mA |
| Alarm:  | 56 mA |
| AC Fail (not backlit):  | 25 mA |

**Figure 1-2: Wiring to Terminals**

### SW1 DIP Switch Settings

The UP position on SW1 is the OFF state. Refer to Figure 1-3 for an explanation of DIP switch positions. SW1 switch settings are as follows:

- 1 - ON (DOWN) = Receive/Transmit, OFF (UP) = Receive only.

Set switch 1 to OFF (UP) position for all LCD-40 Series Annunciators except the last (or only) annunciator on EIA-485 loop. Set switch to ON (DOWN) position for the last or only annunciator on EIA-485 loop to allow transmission of a supervision signal (and function switch depressions on the LCD-40) back to the FACP. *The last or only annunciator must be set for Receive/Transmit (switch 1 in the DOWN position).*

A break (open circuit) in the power or EIA-485 connections creates an LCD-40 Series Annunciator fault at the MS-9200 panel. All annunciators before the break will continue to display information (*but the function switches on the LCD-40s will no longer operate*).

- 2 - LCD-40 Only (not used on LCD-40L)

ON (DOWN) = Key-switch enabled, OFF (UP) = Key-switch disabled.

Switch 2 set to ON (DOWN) position enables key-switch operation. The key-switch may now be used to enable the LCD-40 membrane switches, allowing remote switch functions, or lockout the switches, preventing remote switch functions.

Switch 2 set to OFF (UP) position disables the key-switch operation. Refer to Operation Section for key-switch function description.

- 3 - ON (DOWN) = Piezo sounder enabled, OFF (UP) = Piezo sounder disabled.

**CAUTION:** Piezo sounder must not be disabled without prior approval of the Local Authority Having Jurisdiction (LAHJ).

- 4 through 8 - Future use.

DOWN POSITION = ON STATE

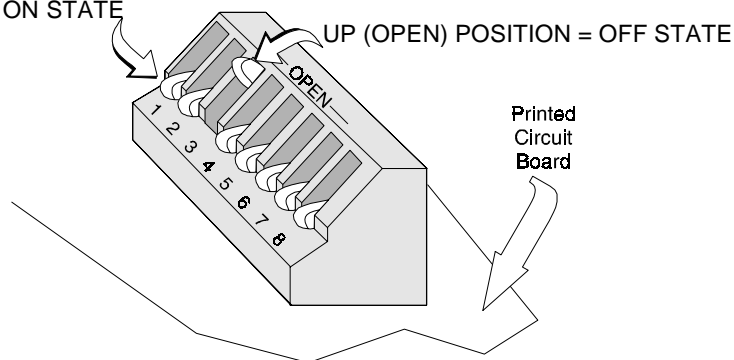

**NOTE - SW1 DIP switch settings as illustrated in Figure 1-3 are as follows:**

- 1) DIP switch 1: ON (DOWN) = Receive/Transmit. This setting is used for the last or only LCD-40 Series Annunciator on the EIA-485 loop.
- 2) DIP switch 2: Used on LCD-40 only - ON (DOWN) = Membrane function switches enabled.
- 3) DIP switch 3: OFF (UP) = Piezo sounder disabled (requires approval of LAHJ).
- 4) DIP switches 4 - 8: Not used.

**Figure 1-3: DIP Switch Settings Example**

## Typical Configuration

The LCD-40 Series Annunciators mimic the MS-9200 display, have full point-display capacity and require no programming. The LCD-40 offers multiple annunciator locations with the capability of remote Acknowledge, Signal Silence, Drill and Reset functions.

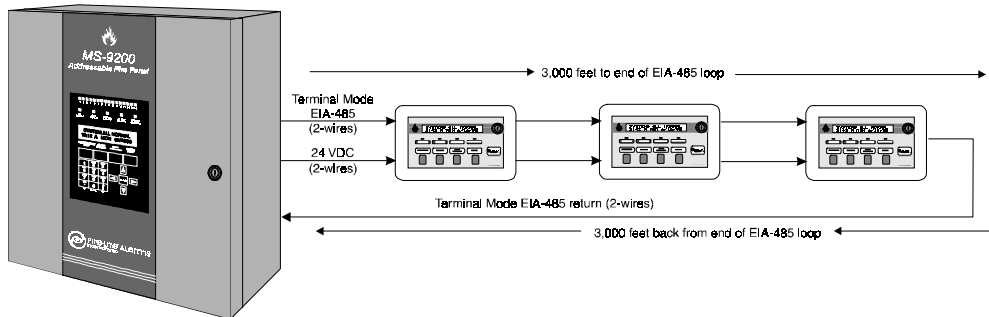

### NOTES:

- 1) **EIA-485:** Maximum of 6,000 feet total cable length from FACP to annunciator and back to FACP for supervision (3,000 feet maximum to last LCD-40). Circuit is power-limited.
- 2) Up to 32 LCD-40 Series Annunciators may be used on the EIA-485 circuit. The MS-9200 can power a maximum of five annunciators. If additional annunciators are connected, the Fire•Lite FCPS-24F may be used to supply additional power. (Power supplies used for this purpose must have their negative terminals commoned together).
- 3) Between each LCD-40 Series annunciator are four wires: A twisted-shielded pair for data communications and a pair for 24 VDC power. The return circuit only requires two wires for data communication supervision, wired from the last or only annunciator on the loop.

**Figure 1-4: Typical Configuration**



## Section Two: Operation

### Display Patterns

The LCD-40 Series Annunciators directly display (mimic) the information on the MS-9200 main circuit board LCD display with the following exceptions:

- Upon power-up, the LCD-40 Series may display the following message until a valid message is received from the MS-9200.



SYSTEM POWER UP  
WAITING FOR THE 9200

- If an LCD-40 Series Annunciator fails to receive communications from the panel for a period of over 30 seconds, it will activate its local sounder (if so programmed) and display the following message:



COMMUNICATIONS FAIL

- When placing the host MS-9200 into some aspects of the Programming Mode, the annunciator will display the following message:



PROGRAMMING THE  
MS-9200 PANEL

The message shown above will appear at the Level One passcode for (1) Autoprogram, (2) Point Edit, (3) System Edit, (4) Passcode Entry and (5) Load. The same message will also appear at the Level Two passcode for (1) Disable, (2) Clear History and (4) Time.

## Switch Functions - LCD-40 Only

### Key-switch

The key-switch is used to enable and disable the operation of the function switches if switch 2 on DIP switch SW1 has been placed to the ON (DOWN) position.

To enable the Acknowledge, Silence, Drill and Reset function switches, insert a standard Fire•Lite key into the key-switch located at the top right corner of the LCD-40. Make certain the key is inserted completely before attempting to turn it. Turn the key clockwise until it stops. Leave the key inserted while pressing the function switches. When finished with the function switches, turn key-switch counterclockwise to disable function switches.

Key-switch (shown in Off Position)

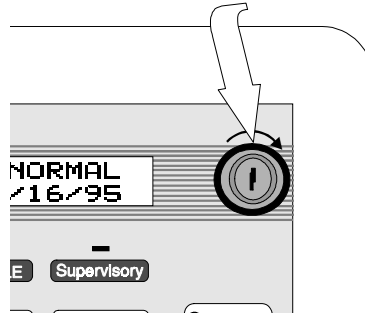

*Note: The key-switch should normally be in the disabled position (fully counterclockwise), with the key removed and access to the key restricted to authorized personnel only. Do not leave the key unattended in the LCD-40.*

### Acknowledge

When the Acknowledge switch is pressed and released, the LCD-40 sends an Acknowledge command to the control panel. Pressing the Acknowledge switch silences the local piezo sounder, the sounders located in all other system annunciators and the sounder located on the Fire Alarm Control Panel's main circuit board. It will also change all flashing system LEDs to steady on. Only one press is necessary regardless of the number of new alarms, troubles or supervisory signals.

An acknowledge message is also sent to the printer and the history files in the MS-9200. Multiple active events (alarms, troubles, supervisories) are scrolled on the display at a one second rate, but may be held for sequential display by pressing and holding the Acknowledged switch.

When more than one event exists, the first press of the Acknowledge switch silences system piezo sounders and changes all flashing LEDs to steady on. The second press of the switch stops the scrolling and holds the event on the display for one minute. Subsequent pressing of the switch 'steps' through each active event.

### Silence

When the Silence switch is pressed and released, the LCD-40 sends a Signal Silence command to the control panel. The Silence switch performs the same functions as the Acknowledge switch. In addition, if an alarm exists, it turns off all silenceable circuits and causes the FACP ALARM SILENCE LED to turn on while the LCD-40 will display a 'silenced' message. It also sends an ALARM SILENCED message to the printer and the history file within the MS-9200. A subsequent new alarm will resound the appropriate Notification Appliance Circuits (NACs) and local sounders.

**Drill: Hold 2 Sec.**

When the Drill switch is pressed and held for at least two seconds (time required to prevent accidental activations), the LCD-40 will transmit a drill command to the control panel. This command causes the FACP to turn on both main panel NAC outputs and all silenceable circuits (all C300/C304 modules/NACs that are programmed silenceable). In the event that the system was previously silenced, the drill command will also turn off the ALARM SILENCE LED. The 'MANUAL EVACUATE' message is shown on the LCD-40 display. The same message is sent to the FACP display, printer and history files. The Silence switch operates on *silenceable* NAC outputs only.

**Reset**

When the System Reset switch is pressed and released, the LCD-40 sends a Reset command to the control panel. This will turn off all C300/C304 modules and Notification Appliance Circuits, temporarily turns off resettable power to 4-wire detectors, causes a 'SYSTEMS ALL NORMAL' message to be displayed on the LCD-40, and sends a 'SYSTEM RESET' message to the FACP display, printer and MS-9200 history files. It also turns on all system LEDs, piezo sounders and LCD display segments as long as the Reset switch is held (lamp test). Any alarm or trouble that exists after a Reset will resound the system.

**LED Indicators - All LCD-40 Series Annunciators****Power**

This is a green LED which illuminates if AC power is applied to the host FACP. The green LED will turn off if AC power to the host FACP is lost.

**Fire Alarm**

This is a red LED that flashes when one or more fire alarms occur. It illuminates steadily when an Acknowledge or Silence switch is pressed. The Alarm LED turns off when the Reset switch is pressed.

**Supervisory**

This is a yellow LED that flashes when one or more supervisory conditions occur, such as a sprinkler valve tamper condition. It illuminates steadily when an Acknowledge or Silence switch is pressed. It turns off when the Reset switch is pressed.

**Trouble**

This is a yellow LED that flashes when one or more trouble conditions occur. It stays on steady when an Acknowledge or Silence switch is pressed. The LED turns off when all trouble conditions are cleared. This LED will also illuminate if the microprocessor watchdog circuit within the LCD-40 Series is activated.

## Section Three: Mounting

### LCD-40 Series Annunciator Preparation

The LCD-40 Series Annunciators can be surface mounted in a three-gang electrical box such as the P/N SBB-3 (2.75" depth) or semi-flush mounted in a three-gang electrical box, P/N 10103 or equivalent, with a minimum depth of 2.187". The LCD-40 Series Annunciators cannot be mounted in three gangable electrical switch boxes connected together. Select and remove the appropriate knockout(s), pull the necessary wires through the knockouts and mount the three-gang box in or on the wall depending on the type of installation desired. *Be certain that power is not applied to the wiring during the installation procedure.*

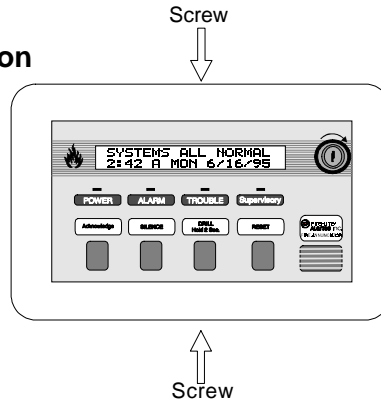

**Note:** To ensure static protection, all enclosures, including the LCD-40 Series electrical box, must be connected to earth ground! Never use the shield for grounding purposes.

To mount the LCD-40 Series Annunciators in an electrical box, the trim ring must first be removed. The trim ring is held in place by two screws inserted through the top and bottom edge as illustrated. Removal of the trim ring will expose a metal flange with mounting holes.

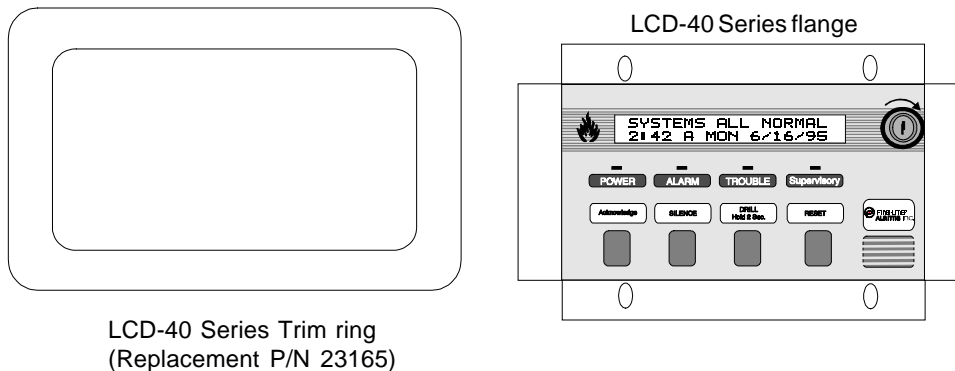

**Figure 3-1: LCD-40 Series Hardware**

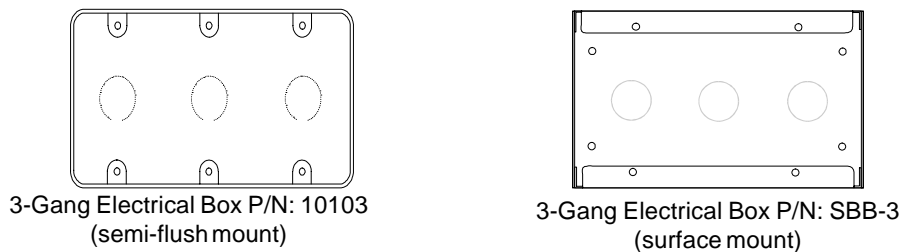

**Figure 3-2: LCD-40 Series Backboxes**

## Semi-flush Mount Backbox

Remove the plug-in terminal blocks from the LCD-40(L) circuit board. Connect the EIA-485 and power wiring into the terminal block positions illustrated in Figures 1-1, 4-1 and 4-2. Plug the terminal blocks back into the P1 and P2 connectors on the back of the annunciator.

Set DIP switch SW1 for the desired options (refer to Figure 1-2).

Carefully insert the LCD-40(L) into the three-gang electrical box and attach it using the four mounting holes on the LCD-40(L) flange and the four screws provided for this purpose. Replace the trim ring and secure with the two screws which were previously removed. Adjust the plastic trim ring to the surface of the wall before tightening the screws. *Do not overtighten.*

**CAUTION!** The LCD-40 Series can **ONLY** be semi-flush mounted in a three-gang electrical box, P/N 10103 or equivalent, with a minimum depth of 2.187". The LCD-40 Series **cannot** be mounted in three gangable electrical switch boxes connected together.

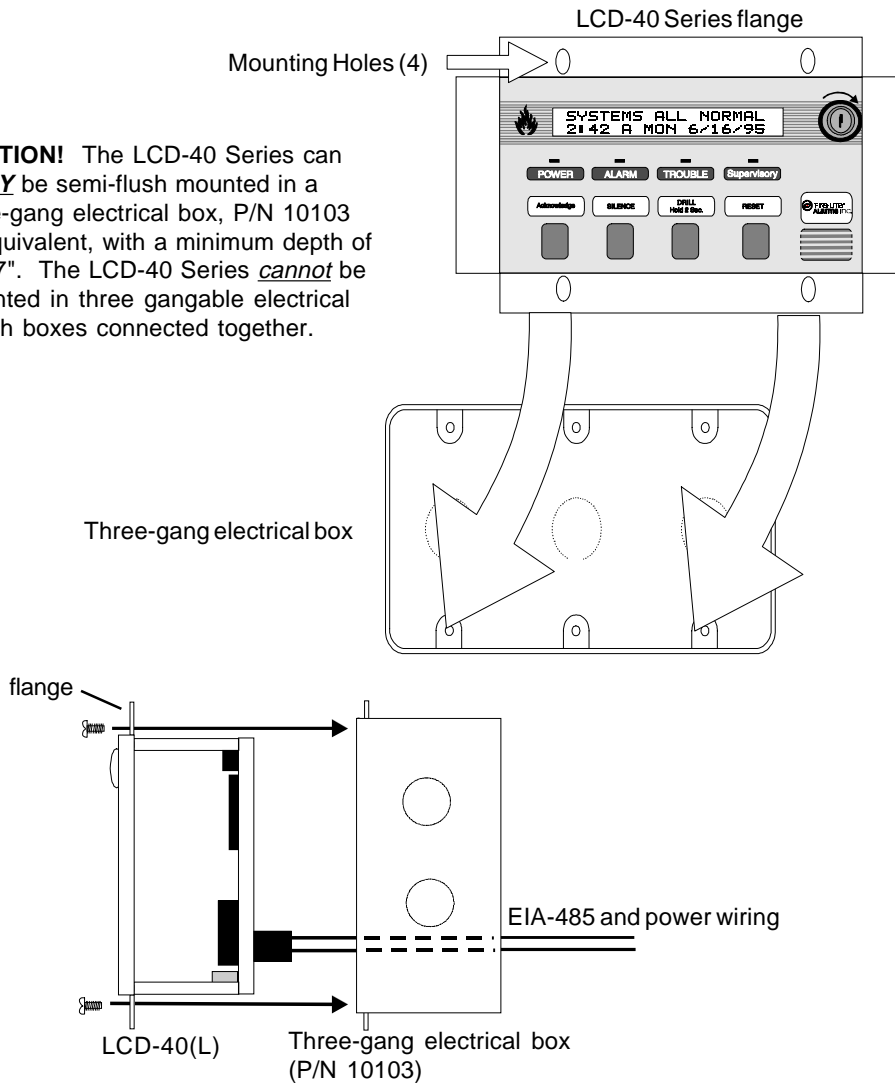

**Figure 3-3: Semi-flush Mounting**

## Surface Mount Backbox

Remove the plug-in terminal blocks from the LCD-40(L) circuit board. Connect the EIA-485 and power wiring into the terminal block positions illustrated in Figures 1-1, 4-1 and 4-3. Plug the terminal blocks back into the P1 and P2 connectors on the back of the annunciator circuit board.

Set DIP switch SW1 for the desired options (refer to Figure 1-2).

Carefully insert the LCD-40(L) into the three-gang electrical box and attach it using the four mounting holes on the LCD-40(L) flange and the four screws provided for this purpose. Replace the trim ring and secure with the two screws which were previously removed. *Do not overtighten.*

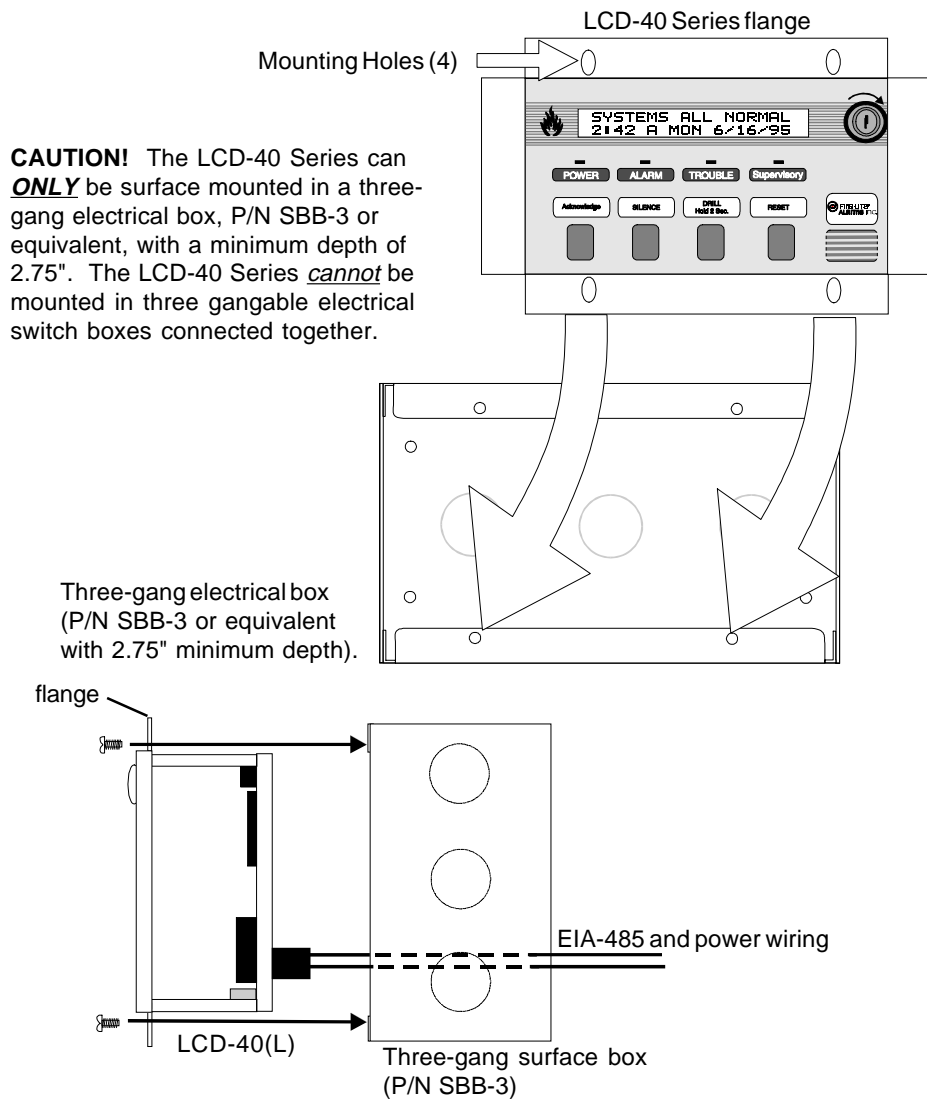

**Figure 3-4: Surface Mounting**

## Section Four: LCD-40 Series Electrical Connections

The LCD-40 Series Annunciators can be powered by the MS-9200 24VDC nominal power or from a remote UL listed, filtered power supply such as the Fire•Lite FCPS-24F. The power run to the annunciator must be power-limited but need not contain a power supervision relay since loss of power is inherently supervised through loss of communication with the annunciator. Maximum LCD-40 Series current draw from the power supply (under normal and alarm conditions) is 56 mA. Maximum current draw from the control panel's secondary power source (batteries) under loss of AC power is 25 mA, since the LCD backlight is turned off during AC loss. Backlighting is turned back on during AC loss only for alarm conditions in the system.

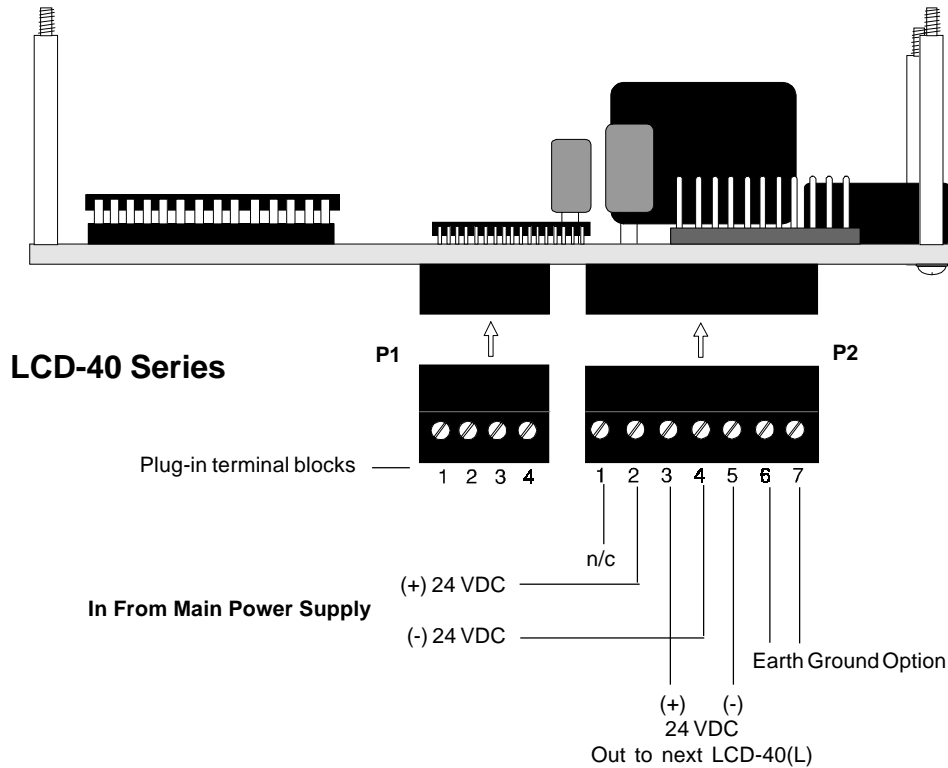

**Notes:**

- 1) All connections are power-limited and supervised.
- 2) 12 to 18 AWG wire for 24 VDC circuit is acceptable.
- 3) Power wire distance limitation is set by 1.2 volt maximum line drop from source to end of circuit.

**Figure 4-1: Power Connection**

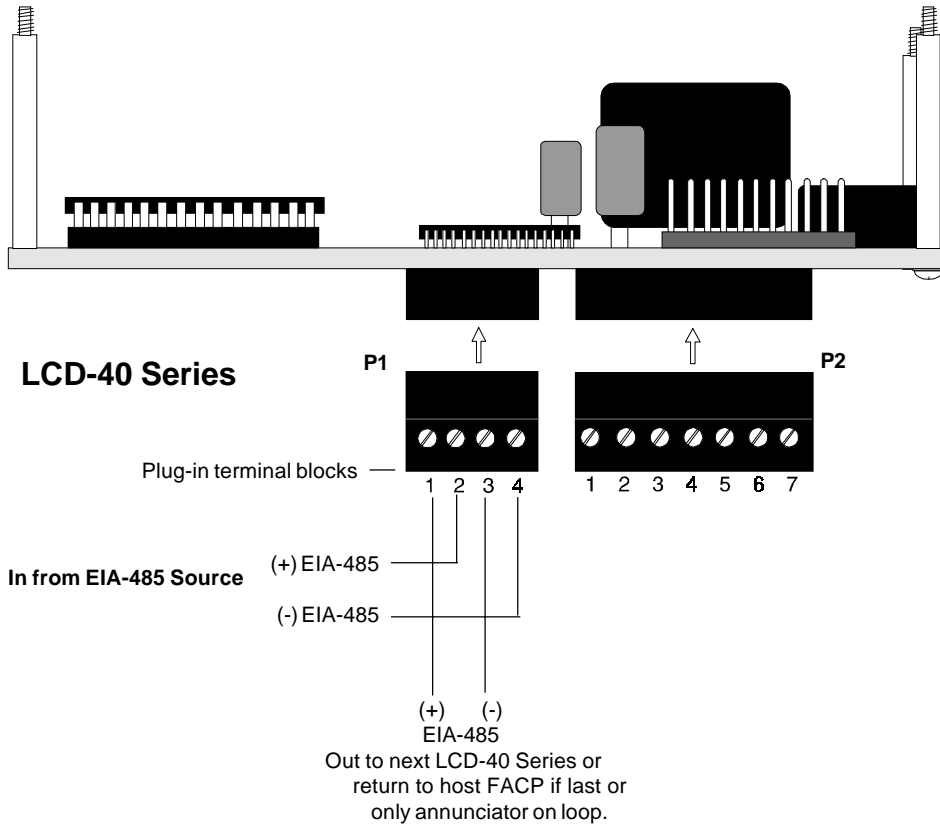

**Notes:**

- 1) All connections are power-limited and supervised.
- 2) A maximum of 32 LCD-40 Series Annunciators may be connected to this circuit.
- 3) 6,000 feet maximum distance (@ 18 AWG) between the panel, annunciators and return to the panel.
- 4) Use overall foil/braided-shield twisted pair cable suitable for EIA-485 applications (refer to Section Five for shield termination information).
- 5) The EIA-485 circuit is rated at 5.5 VDC maximum and 60 mA maximum.
- 6) The LCD-40 Series Annunciators have resistors built into the circuit board at the In (Terminals 2 & 4) and the Out (Terminals 1 & 3) for impedance matching. There is no need for the installer to add impedance matching resistors.

**Figure 4-2: EIA-485 Connection**



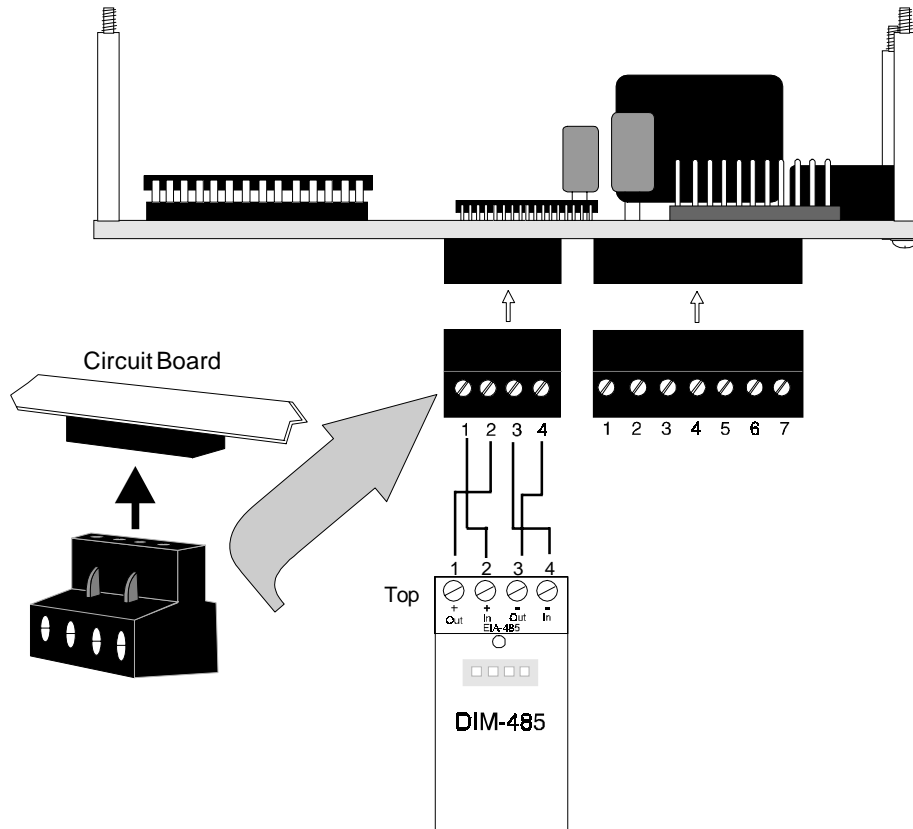

| DIM-485 CONNECTIONS  |                                      |
|----------------------|--------------------------------------|
| DIM-485              | LCD-40 Series <sup>3</sup>           |
| Terminal 1 - OUT (+) | P1 Terminal 2 - IN (+)               |
| Terminal 2 - IN (+)  | P1 Terminal 1 <sup>2</sup> - OUT (+) |
| Terminal 3 - OUT (-) | P1 Terminal 4 - IN (-)               |
| Terminal 4 - IN (-)  | P1 Terminal 3 <sup>2</sup> - OUT (-) |

**Notes:**

- 1) Terminal to terminal wiring is shown between the DIM-485 and one LCD-40 Series Annunciator.
- 2) If more than one LCD-40 Series Annunciator is installed, the wiring to the DIM-485 In (+) Terminal 2 and In (-) Terminal 4 will be from the last installed annunciator (refer to Figure 4-4).
- 3) The LCD-40 Series Annunciators have resistors built into the circuit board at the In (Terminals 2 & 4) and the Out (Terminals 1 & 3) for impedance matching. There is no need for the installer to add impedance matching resistors.
- 4) Connect wiring to DIM-485 terminals before plugging DIM-485 into connector J11 of the MS-9200 main circuit board.

**Figure 4-3: DIM-485 Connections**

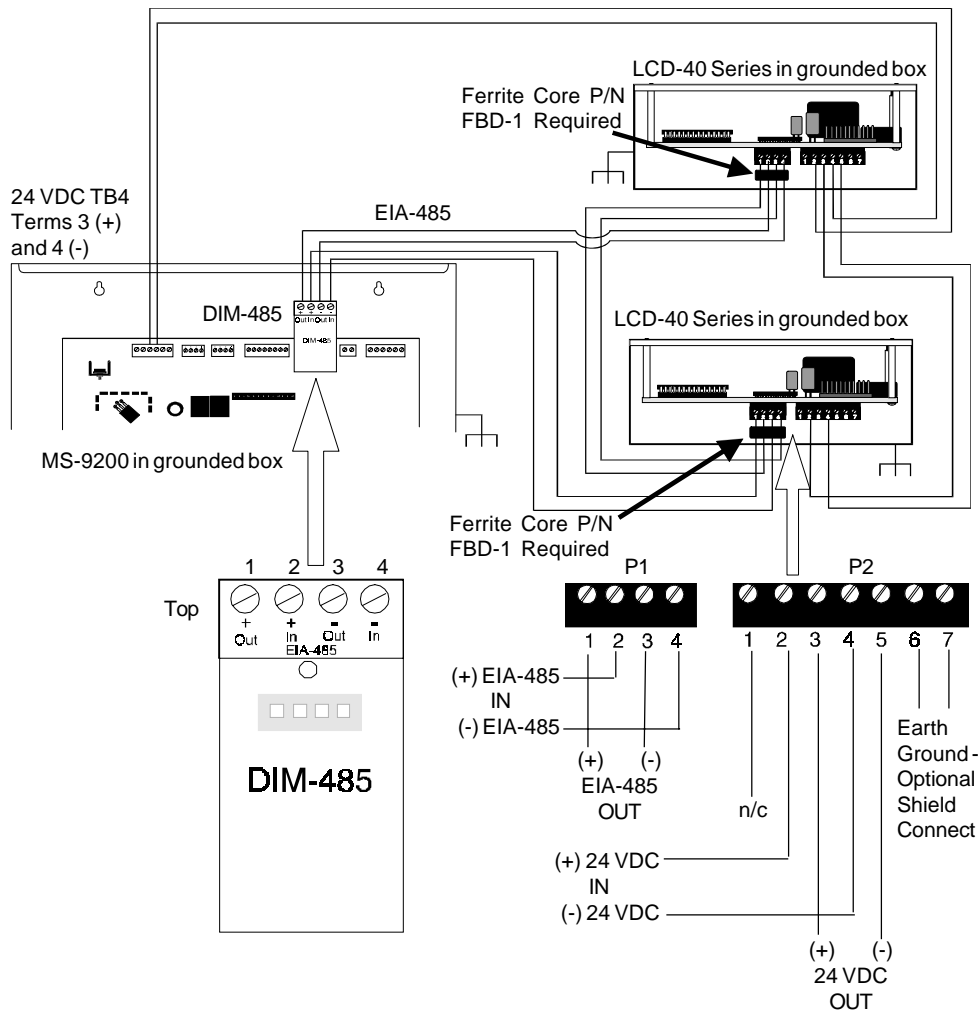

### DIM-485 Installation

**CAUTION!** Connect all wiring to the DIM-485 terminals before plugging the DIM-485 into connector J11 on the MS-9200 main circuit board.

- 1) Carefully align the DIM-485 connector with the four pins on connector J11 of the MS-9200.
- 2) Press firmly on the DIM-485 connector to seat properly on connector J11 being careful not to bend any pins.
- 3) Be certain to secure the DIM-485 module to the MS-9200 and to keep all wiring from mechanically interfering with the DIM-485.

### Note:

- 1) Ferrite Core P/N FBD-1 is required to meet FCC Part 15 requirements if the EIA-485 wiring is not in conduit. Twisted, shielded wire is recommended for the EIA-485 communications loop.
- 2) Six conductor overall shielded wire may be used for the four EIA-485 wires and the two power wires. It is, however, strongly recommended that the power and communication wires be separate whenever possible.

**Figure 4-4: Wiring FACP to LCD-40 Series**

## Section Five: EIA-485 Shield Terminations

The EIA-485 circuit must be wired using a twisted-shielded pair cable having a characteristic impedance of 120 ohms, +/- 20%. Do not run cable adjacent to, or in the same conduit as, 120-volt AC service, noisy electrical circuits that are powering mechanical bells or horns, audio circuits above 25 V<sub>RMS</sub>, motor control circuits, or SCR power circuits.

**Note:** To ensure static (ESD - electrostatic discharge) protection, all enclosures, including the LCD-40 Series electrical box, must be connected to earth ground! Never use the EIA-485 shield for this purpose. The EIA-485 shield is for radiated noise emission protection (RFI, EMI). Refer to the following figures.

The EIA-485 shield should be terminated as follows:

**When the EIA-485 shield is not in conduit:** The EIA-485 loop allows the FACP to communicate with the LCD-40 Series Annunciators. The shield for the EIA-485 loop must be connected to earth ground at the FACP but must be left floating (no connection) at the annunciator if it is the first or only device on the EIA-485 loop. If a second annunciator is connected, the shield leaving the first annunciator must be left floating. The shield entering the second annunciator must be connected to the 3-gang box or Earth Ground terminal (P2-7) on the second annunciator. If additional annunciators are connected, the shield leaving each enclosure must be left floating and the shield entering each must be connected to the 3-gang box or the Earth Ground Terminal (P2-7) on the annunciator.

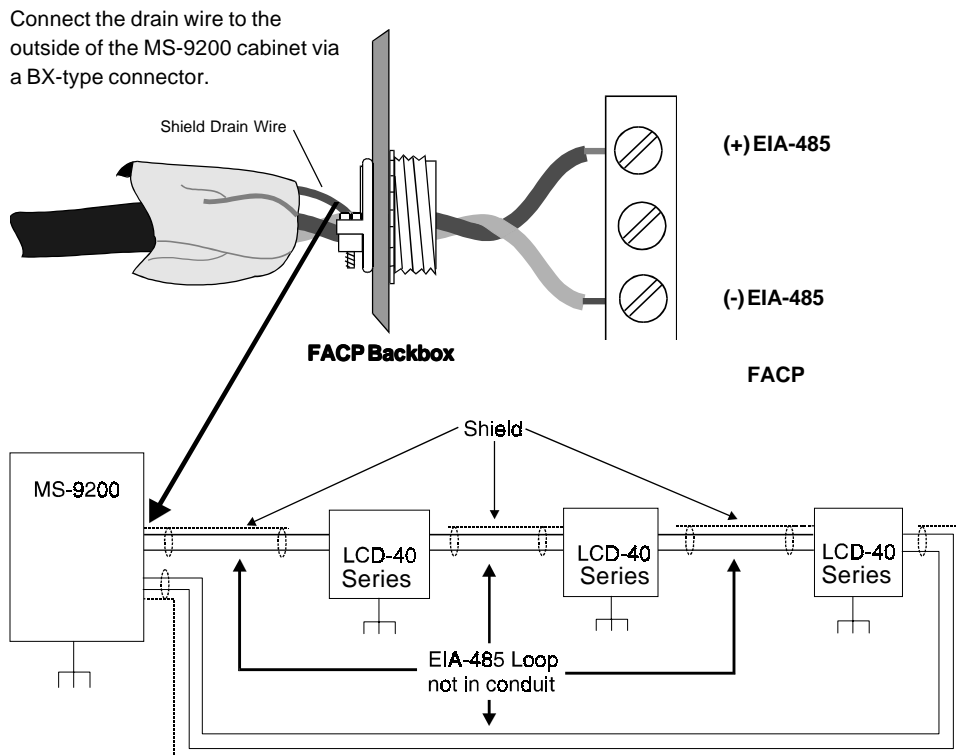

**When the EIA-485 shield is in full conduit:** The EIA-485 loop allows the FACP to communicate with the LCD-40 Series Annunciators. The shield for the EIA-485 loop must be connected to earth ground at the FACP (both exiting and entering the FACP), but must be left floating (no connection) at the annunciator if it is the first or only device on the EIA-485 loop. If a second annunciator is connected, the shield leaving the first annunciator must be left floating. The shield entering the second annunciator must be connected to the Earth Ground Terminal (P2-7) on the second annunciator. If additional annunciators are connected, the shield leaving each annunciator must be left floating and the shield entering the following unit must be connected to the Earth Ground Terminal (P2-7) on the annunciator.

*Caution! Do not allow the floating (no connection) end of the shield to contact the conduit. The floating end should be insulated from earth ground.*

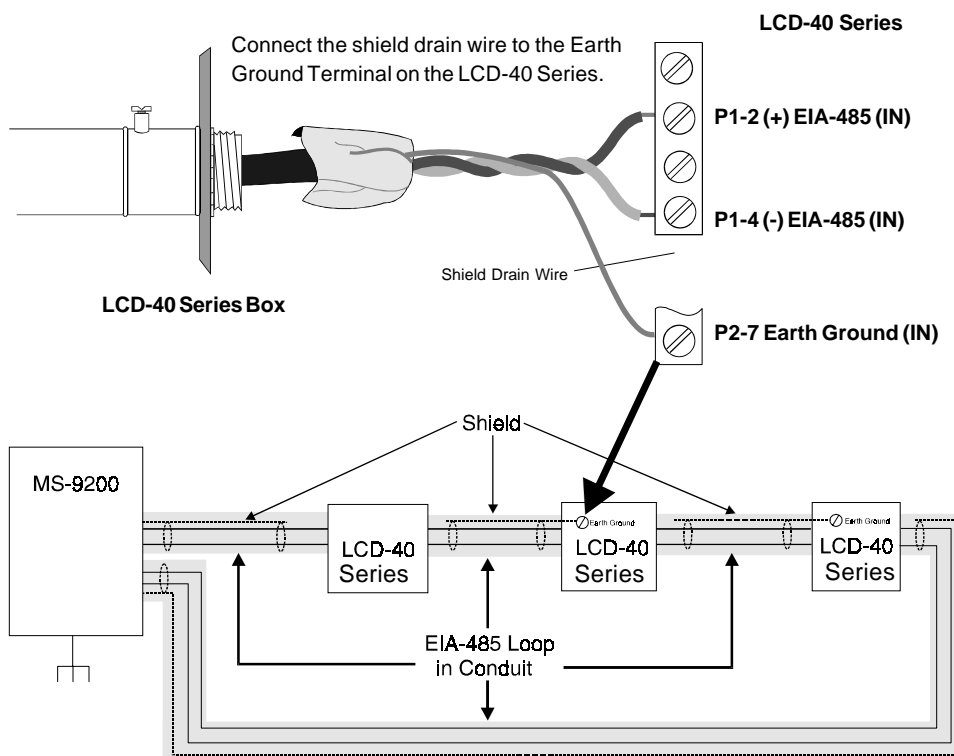

**Notes:**

- 1) Power-limited 24 VDC regulated power may be run in the same conduit as the EIA-485 wiring.
- 2) Twisted, shielded wire is recommended for the EIA-485 communications loop.
- 3) Each LCD-40 Series electrical backbox is connected to earth ground via the conduit.
- 4) Shield is connected to the FACP cabinet (earth ground) leaving and entering the FACP.

## Section Six: Programming MS-9200

The MS-9200 must be programmed to allow use of the LCD-40 Series Annunciators. In order to program the MS-9200, make certain the main circuit board 'Write Protect' switch (SW1) is in the down position and then press the ENTER key on the panel keypad. After pressing ENTER, the screen shown below is displayed:

**1=PROGRAMMING  
2=RD STATUS 3=AC/BAT**

To enter the programming mode, press '1'. The display will read as follows:

**KEY IN 5 DIGIT  
PASSWORD, THEN ENTER**

Enter the Level 1 password. The following screen will appear:

**0=CLR 1=AUTO 2=POINT  
3=SYS 4=PWORD 5=LOAD**

Press '3' to enter System Edit. The system edit screen may appear as shown below for FACP firmware P/N 73750 or greater (note that previous programming may have altered some **N** or No designations to **Y** or Yes):

**V=N I=N A=N P=N C=N  
A/U=N L/P=N S=4 R=4**

Use the Left and Right arrow keys to move to the L/P option. Once at the L/P option, to enable the LCD-40 Series Annunciator option, use the Up and Down arrow keys to scroll to the L (for LCD-40 Series Annunciator) choice. The LCD-40 Series can now communicate with the MS-9200.

To leave programming mode, press the BACKSPACE (left arrow) key repeatedly until program mode is exited.

## Notes

## Notes

## **Limited Warranty**

**Fire-Lite**® warrants its products to be free from defects in materials and workmanship for eighteen (18) months from the date of manufacture, under normal use and service. Products are date stamped at time of manufacture. The sole and exclusive obligation of **Fire-Lite**® is to repair or replace, at its option, free of charge for parts and labor, any part which is defective in materials or workmanship under normal use and service. For products not under **Fire-Lite**® manufacturing date-stamp control, the warranty is eighteen (18) months from date of original purchase by **Fire-Lite**®'s distributor unless the installation instructions or catalog sets forth a shorter period, in which case the shorter period shall apply. This warranty is void if the product is altered, repaired or serviced by anyone other than **Fire-Lite**® or its authorized distributors or if there is a failure to maintain the products and systems in which they operate in a proper and workable manner. In case of defect, secure a Return Material Authorization form from our customer service department. Return product, transportation prepaid, to **Fire-Lite**®, 12 Clintonville Road, Northford, Connecticut 06472-1653.

This writing constitutes the only warranty made by **Fire-Lite**® with respect to its products. **Fire-Lite**® does not represent that its products will prevent any loss by fire or otherwise, or that its products will in all cases provide the protection for which they are installed or intended. Buyer acknowledges that **Fire-Lite**® is not an insurer and assumes no risk for loss or damages or the cost of any inconvenience, transportation, damage, misuse, abuse, accident or similar incident.

**Fire-Lite**® GIVES NO WARRANTY, EXPRESSED OR IMPLIED, OF MERCHANTABILITY, FITNESS FOR ANY PARTICULAR PURPOSE, OR OTHERWISE WHICH EXTEND BEYOND THE DESCRIPTION ON THE FACE HEREOF. UNDER NO CIRCUMSTANCES SHALL **Fire-Lite**® BE LIABLE FOR ANY LOSS OF OR DAMAGE TO PROPERTY, DIRECT, INCIDENTAL OR CONSEQUENTIAL, ARISING OUT OF THE USE OF, OR INABILITY TO USE **Fire-Lite**® PRODUCTS. FURTHERMORE, **Fire-Lite**® SHALL NOT BE LIABLE FOR ANY PERSONAL INJURY OR DEATH WHICH MAY ARISE IN THE COURSE OF, OR AS A RESULT OF, PERSONAL, COMMERCIAL OR INDUSTRIAL USE OF ITS PRODUCTS.

This warranty replaces all previous warranties and is the only warranty made by **Fire-Lite**®. No increase or alteration, written or verbal, of the obligation of this warranty is authorized.

"**Fire-Lite**" is a registered trademark.



12 Clintonville Road,  
Northford, CT 06472  
Phone: (203) 484-7161  
FAX: (203) 484-7118